

**EFORT**

# ESR10-3-650Z15

ESR10-3-650Z15 is a customized SCARA robot specialized in screw driving and dispensing, Maxium payload 10 kg with maxium reach 660.5 mm.

**Highlights**

1. High rhythm and high precision  
Tailored for high-speed and high-precision automatic screw locking tasks and adhesive coating.
2. High rigidity and low vibration  
Robot body mode and rigidity enhancement, combined with vibration suppression and active vibration suppression functions, effectively reduce vibration.
3. Easy to maintain and scalable  
The detachable structure of cables and batteries allows for the replacement of robots inside the device, and the built-in camera network cable enables various communication extensions.

**Applications**

It can be used in handling, sorting, assembly, etc.

**Industries**

Suitable for industries such as electronic manufacturing, toys, household appliances, instruments, and equipment.



## SPECIFICATIONS

<b>Model</b>		ESR10-3-650Z15
<b>Reach</b>		660.5 mm
<b>Max. payload on wrist</b>	Rated	5 kg
	Maximum	10 kg
<b>Robot weight</b>		25 kg
<b>Maximum speed</b>	J1+J2	8850 mm/sec
	J3	800 mm/sec
	J4	/
	J1	±132°
<b>Motion range</b>	J2	±150°
	J3	150 mm
	J4	/
	J1+J2	±0.025 mm
<b>Repeatability</b>	J3	±0.01 mm
	J4	/
	<b>Standard cycle time</b>	
<b>J4 allowable moment of inertia</b>	Rated	/
	Maximum	/
<b>Electric lines</b>		D-Sub 15-Pin
<b>Pneumatic lines</b>		φ4 mmx1, φ6 mmx2
<b>J3 downward force</b>		200 N
<b>Installation</b>		Floor
<b>Installation enviroment</b>	Ambient temperature	5~40°C
	Ambient humidity	RH≤80% (No dew nor frost allowed)

\*The final interpretation right belongs to EFORT Intelligent Robot Co., Ltd. Any updates will be made without prior notice.

## OPERATING SPACE

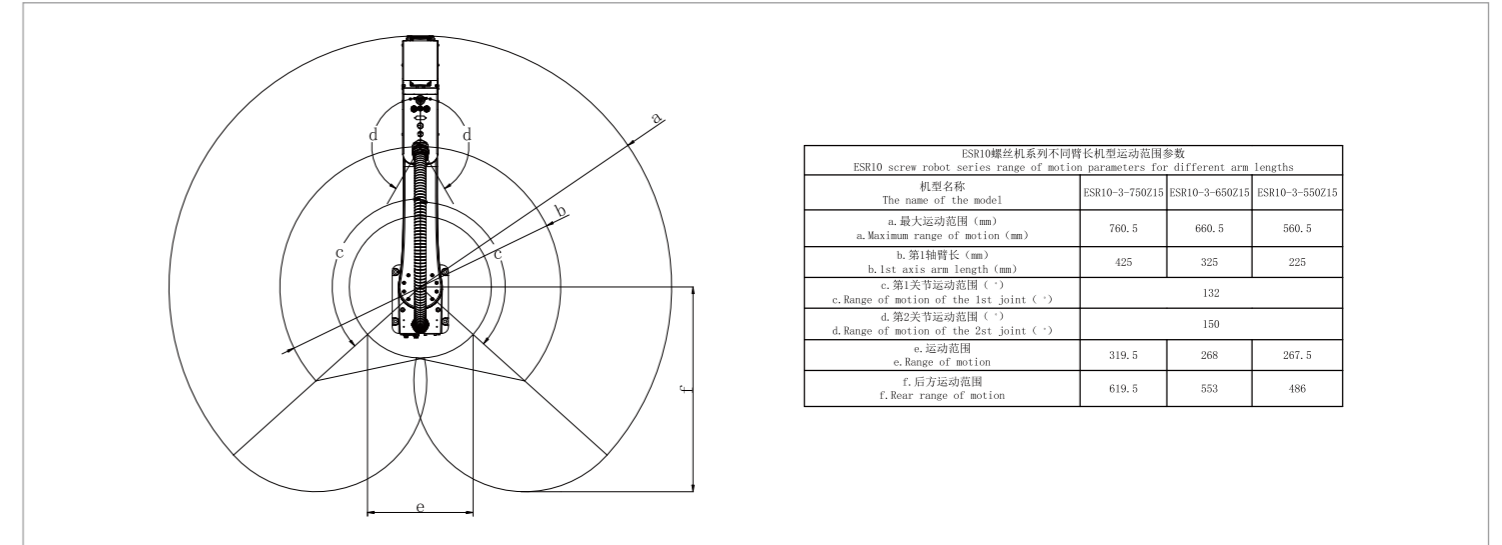

## BASE MOUNTING SIZE

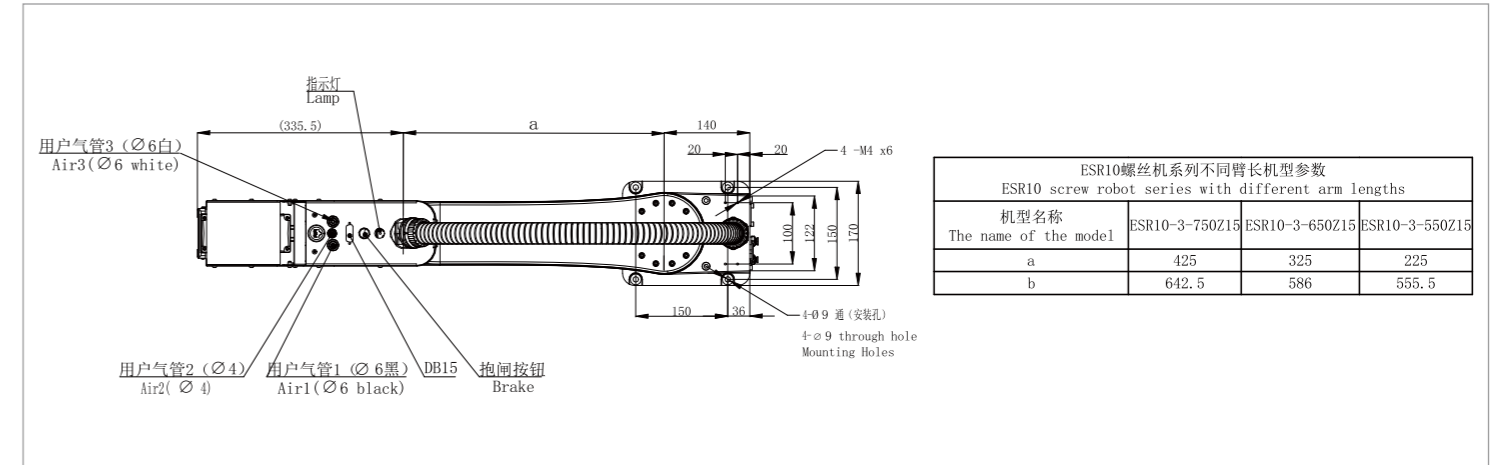

## END FLANGE MOUNTING SIZE

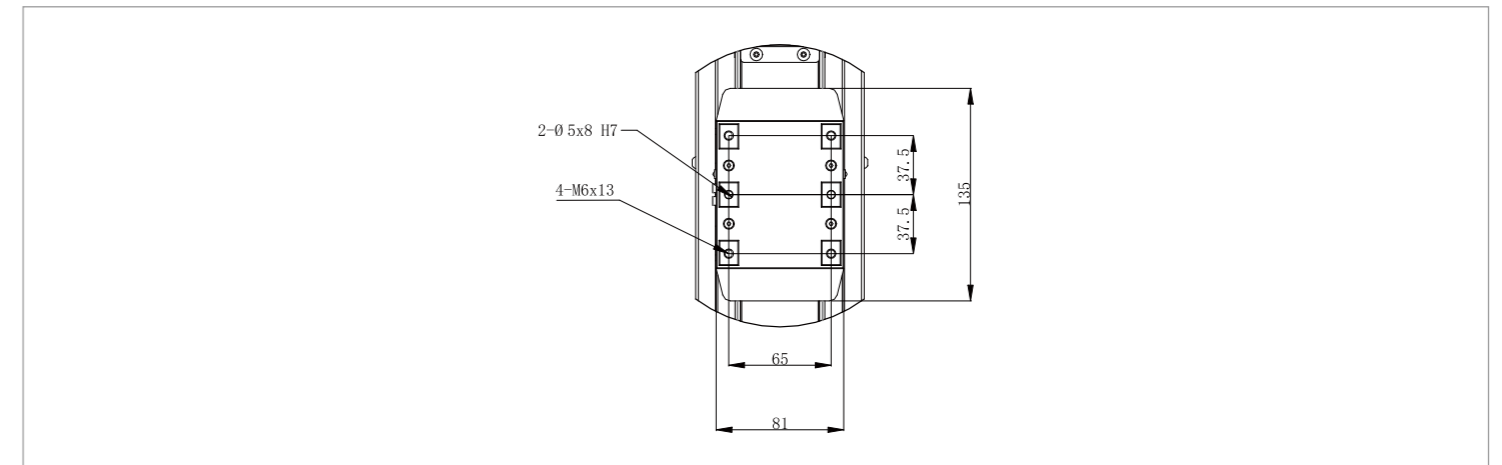

Information Release Time 2025/04

PHONE: (00 86) 400-052-8877  
 ADDRESS: No. 96, Wanchun East Road, Wuhu,  
 China (Anhui) Pilot Free Trade Zone  
 WWW.EFORT.COM.CN

**EFORT Intelligent Robot Co., Ltd.**